

SPECIAL-MODEL

LPR-2515

The new steering joystick - more comfortable, compact, and intuitive than any steering wheel

- Perfect ergonomic design ensures longer operating sessions
- Reduced movement effort during operation saves time and energy
- Force feedback functionality supports intuitive control

CE – konform



TECHNICAL DATA

Handle inclination	5° standard (adjustable)
Housing material	black anodized aluminum, black plastic
Feedback angle	±25°
Guide angle	±15°
Actuation	spring-centered neutral position
Direction of operation	x-axis
IP code of housing	IP54
Temperature range	-40 °C up to +80 °C
Connection	cable / plug

Electronics topology	Kat 2 according to EN13849, Kat 3 possible
Signal output	CAN / J1939
Power supply	1x 12 V DC ±25 % / 24 V DC ±25 %
Idle current consumption	<100 mA at 12 V / <200 mA at 24 V
Current consumption in motion	<2000 mA at 12 V / <4000 mA at 24 V

Features
Customer-specific configuration options (handle / control elements)

Article master number 3520F01

Typical

APPLICATION AREAS



Agricultural



Construction machine



Crane



Rails



Logistics



Ship

More information about our joysticks can be found here: www.fsg-sensors.de



SPECIAL-MODEL

LPR-2515

DIMENSIONAL DRAWINGS

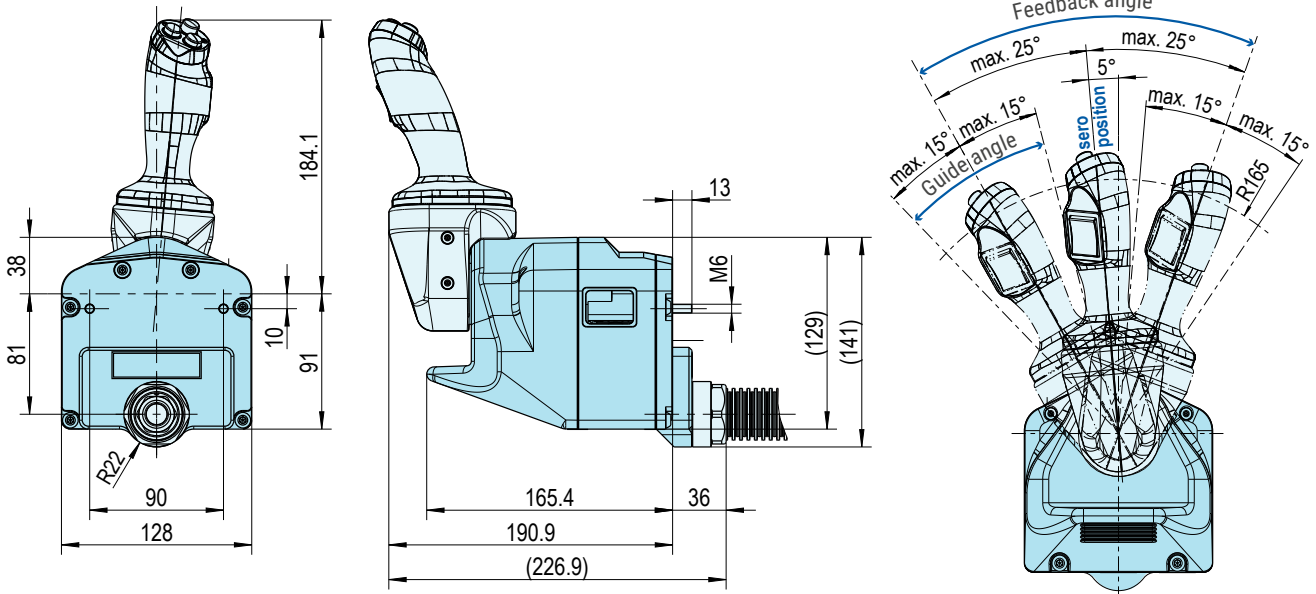

CONNECTION (EXAMPLE)

PIN	Function
1	12 V KI 30
2	12 V KI 15
3	SW nc+
4	SW nc-
5	CAN high
6	CAN 120 R
7	CAN low
8	SW no+
9	SW no-
10	0 V KI 15
11	0 V KI 30
12	not connected

Custom-specific wiring configuration

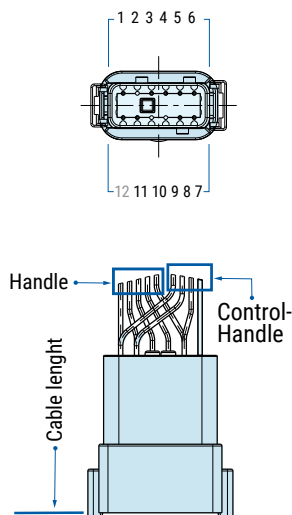

Optional available HANDLE-VARIANTS



ST-2000



ST-2010



ST-2020





ST-2025

CONTACT

If you have any questions about this or any other FSG product, please do not hesitate to contact us.

 **BERLIN (HQ)**
Fernsteuergeräte Kurt Oelsch GmbH
Jahnstraße 68 + 70
12347 Berlin

 info@fsg-sensors.de
 www.fsg-sensors.de
 +49 30 6291-1
 +49 30 6291-277

© Fernsteuergeräte Kurt Oelsch GmbH
No guarantee for the correctness, completeness of the contents. The product illustration may differ from original.